

DMV-D(LE) 7../604L
Dual Safety Shutoff Valves with NEMA Type 4x Enclosure
Installation Instructions

SPECIFICATIONS

DMV-D/604L Two normally closed safety shutoff valves in one housing. V1 and V2 are fast opening, fast closing. Two stage and adjustable max. flow on V2. NEMA Type 4x.

DMV-DLE/604L Two normally closed safety shutoff valves in one housing. V1 fast opening, fast closing. V2 is a slow opening, fast closing valve. Adjustable max. flow and adjustable initial lift with V2. NEMA Type 4x.

Body size Flange Size

DMV-D(LE) 702/604L 1" - 2" NPT
DMV-D(LE) 703/604L 1" - 2" NPT

Gases

Natural gas, propane, butane; other noncorrosive gases

Maximum Operating Pressure

7 PSI (500 mbar)UL, FM
5 PSI (350 mbar) CSA

Ambient / Fluid Temperature

-20°F to +150°F; (-30°C to +65°C)

Electrical Ratings

120 Vac 50-60 Hz

Power Consumption with all coils energized

DMV-D(LE) 702: 120 VA
DMV-D(LE) 703: 135 VA

Electrical Connection

Terminal boxes with NPT 1/2" conduit connections

Enclosure Rating

NEMA Type 4x

Operating Time

100 % duty cycle

Classification of Valve V1 and V2

Safety Shut Off Valve:
UL 429
ANSI Z21.21 • CSA 6.5 C/I Valves
FM 7400

Closing Time (Valve 1 & Valve 2)

< 1 second

Opening Time

DMV-D/604: V1 &V2 < 1 sec.
DMV-DLE/604: V1 < 1 sec.; V2 10 to 20 sec. (70 °F)

Main Flow Setting (DMV-D/604 & DMV-DLE/604)

Adjustable on V2: <10 to 100% of total flow

Initial Lift Adjustment (DMV-DLE/604)

Adjustable on V2: 0 to 70 % of total flow

Materials in contact with Gas

Housing: Aluminum, Steel
Sealings on valve seats: NBR-based rubber

Mounting Position

Solenoid upright vertical
to solenoid horizontal

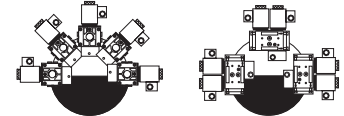

Strainer

23 Mesh, installed in the housing upstream V1

Test Ports

G 1/8 ISO 228 taps available
on both sides upstream of
V1, between V1 and V2 and
downstream of V2, and on both flanges

Position Indication (optional)

Visual Indicator
CPI 400 w/ visual indication and electrical switch (SPDT),

Approvals

UL Listed: File # MH16727
CSA Certified: File # 1010989
FM Approved:File # J.I.1Z6A0.AF
Commonwealth of Massachusetts Approved Product
Approval code G1-1107-35



ATTENTION

- Read these instructions carefully.
- Failure to follow them and/or improper installation may cause explosion, property damage and injuries.
- Installation must be done with the supervision of a licensed burner technician.
- The system must meet all applicable national and local code requirements such as but not limited to the following fuel gas codes: NFPA 54, IFGC (International Fuel Gas Code), or CSA B149.1 (for Canada) or the following equipment codes and standards: CSD-1, NFPA 86, NFPA 37, ANSI Z83.4/CSA 3.7, ANSI Z83.18, ANSI Z21.13/ CSA 4.9, or CSA B149.3 (for Canada).
- Check the ratings in the specifications to make sure that they are suitable for your application.
- Never perform work if gas pressure or power is applied, or in the presence of an open flame.
- Once installed, perform a complete checkout including leak testing, and verify proper operation.

Karl Dungs, Inc

524 Apollo Drive, Suite 10 Lino Lakes, MN 55014 U.S.A.

Phone: (651) 792-8912 Fax: (651) 792-8919 E-mail: info@karldungusa.com

MOUNTING

Recommended Preparation

- Examine the valve for shipping damage.
- The main gas supply must be shut off before starting the installation.
- The inside of the DMV-D(LE)/604L, the flanges, and piping must be clean and free of dirt, remove all dirt and debris before installing the DMV-D(LE)/604L. Failure to remove dirt/ debris could result in valve damage or improper performance.

Recommended Procedure to Mount the Flanges

- Unpack the valve and remove the 8 socket cap head screws using a 6 mm Allen wrench.
- Remove the two white protective plastic covers from the valve body.
- Make sure the o-rings and the grooves in the valve are clean and in good condition.
- Clean the mounting surface of the flanges that comes into contact with the o-ring seal.
- Attach the flanges to the valve body using the M8 socket cap screws supplied. Install the flanges so that the test port on the flange is accessible from the top of the valve.
- Tighten the screws in a crisscross pattern following the recommended torque table below.

Recommended Torque	M8 Screw Size	Screw Size [lb-in]
	134	

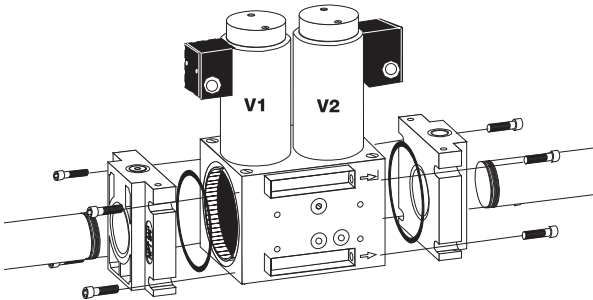

CAUTION: If the flow is not in the same direction of the arrows the valve body or the valve will not operate properly.

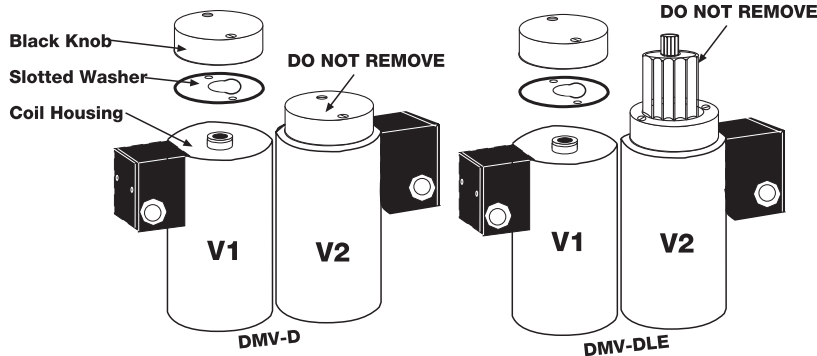

Recommended Piping Procedure

- Use new, properly reamed and threaded pipe.
- Apply good quality pipe sealant, putting a moderate amount on the male threads only. If pipe sealant lodges on the valve seat, it will prevent proper operation. If using LP gas, use pipe sealant rated for use with LP gas.
- Install the DMV-D(LE)/604 with the gas flow matching the direction indicated by the arrows on the casting.
- Do not thread pipe too far. Valve distortion and/or malfunction may result from excess pipe in the valve body.
- Apply counter pressure with a parallel jaw wrench only to the flats on the flange when screwing the pipe into the flanges.
- Do not overtighten the pipe. Follow the maximum torque values listed below.

Recommended Torque for Piping

1"	1-1/4"	1-1/2"	2"	NPT pipe
750	875	940	1190	[lb-in]

- After installation is complete, perform a complete leak test.

Positioning junction boxes

- Locate the black knob on top of Valve 1. There are two screws, the holding screw is recessed and has a blue sealing compound on it, while the pan head screw protrudes from the cap.
- Remove both screws, remove the black knob, remove the slotted washer.
- Remove the coil assembly Valve 1 ONLY .
- Locate the black knob on top of Valve 2. There are two screws, the holding screw is recessed and has a blue sealing compound on it, while the pan head screw protrudes from the cap.
- Loosen the pan head screw until you can freely rotate the coil assembly. Position the coil so that the junction box is in an accessible location to connect to conduit.
- Replace the coil from Valve 1. Position the coil so that the junction box is in an accessible location to connect to conduit.
- Re-install the washer, black cap, and the screws.

CAUTION: Do not adjust or remove any screws or bolts which are sealed with a red colored compound. Doing so will void all approvals and warranties.

WARNING: DO NOT remove the adjustment cap from valve 2. If the adjustment cap is removed, perform the valve leakage test on page 3 - with special attention to the area under the adjustment cap.

PAINTING VALVE

- It is not recommended that this valve be painted. Painting covers date codes and other labels that identify this valve.
- If the valve needs to be painted, a paint free of volatile organic components (VOC's) must be used. VOC's can damage valve o-rings, resulting in external gas leakage over time.
- During the painting process, use measures that will allow the valve's date code and other labeling information to be legible after the paint is dry.

PROTECTION FROM RADIANT HEAT

- Radiant heat must be considered as a heat source that could result in an ambient temperature higher than the rating of this valve.
- Provide proper shielding to protect against radiant heat.

WIRING

NOTE: Use 14 or 16 guage wire rated for 95°C(200°F)

- Remove the wiring box cover and knock out only one of the conduit connections on the side of the terminal box you wish to make your conduit connection to.
- Make electrical connections to the valve, replace cover.



All wiring must comply with local electrical codes, ordinances and regulations.

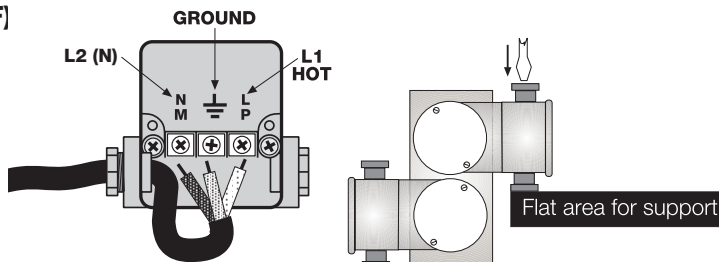

VALVE ADJUSTMENT

Flow Setting

- The valves are factory set with the flow adjustment fully open.
- Locate the black knob on top of **Valve 2**. There are two screws, the holding screw is recessed and has a blue sealing compound on it, while the pan head screw protrudes from the cap.
- Loosen the pan head screw until you can freely rotate the flow adjustment.
- Turn clockwise for less gas or counterclockwise for more gas.
- Check the flow at the burner with an orifice or flow meter.
- Tighten the pan head screw on the adjustment cap.

Initial Lift Adjustment (DMV-DLE/604 only)

The initial lift adjustment varies the initial gas flow through the valve as the valve seat begins to open. This adjustment can vary the initial flow between 0 % and 70% of the total gas flow; 0 to 25% of stroke. All DMV-DLE/604L valves are factory set with no initial lift. To adjust the lift proceed as follows:

- Unscrew the small black cap on top of the flow adjustment cap to expose the initial lift adjustment knob.
- The black cap also serves as tool; turn the cap over and insert it on the slot on the adjustment knob.
- Turn the knob clockwise for a min. initial lift or counterclockwise for a max. initial lift.
- Once the desired initial fast lift has been achieved, reinstall the black cap.

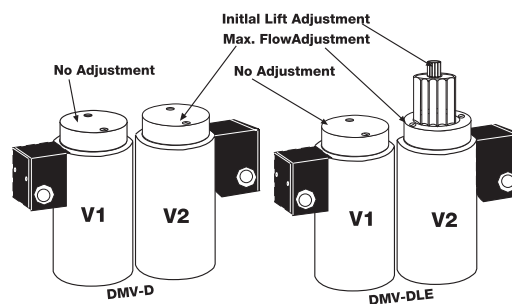

VALVE LEAKAGE TEST

This leak test procedure tests the external sealing and valve seat sealing capabilities of the DMV automatic safety shutoff valve. Only qualified personnel should perform this test.

It is required that this test be done on the initial system startup, and then repeated at least annually. Possibly more often depending on the application, environmental parameters, and the requirements of the authority having jurisdiction.

SETUP

This test requires the following:

- A) Test nipples installed in the downstream pressure tap port of each automatic safety shutoff valve to make the required 1/4" hose connection in step 4.
- B) A transparent glass of water filled at least 1 inch from the bottom.
- C) A proper leak test tube. An aluminum or copper 1/4" rigid tube with a 45° cut at the end that is then connected to a 1/4" flexible hose of some convenient length provides for a more accurate leakage measurement. However, a 45° cut at the end of the 1/4" flexible hose will suffice, but it will not likely be as accurate as the rigid tube.
- D) For detecting external leakages, an all purpose liquid leak detector solution or a soapy water solution is required.

LEAK TEST PROCEDURE

Use the illustration below as a reference.

1. With the upstream ball valve open, the downstream ball valve closed and both valves energized, apply an all purpose liquid leak detector solution to the "External Leakage Test Areas" indicated in the illustration below, to any accessories mounted to the safety valve, and to all gas piping and gas components downstream the equipment isolation valve, and the inlet and outlet gas piping of the automatic safety shutoff valve. The presence of

bubbles indicates a leak, which needs to be rectified before proceeding.

2. Then, de-energize the burner system and verify that both automatic safety shutoff valves are closed.
3. Close the upstream and downstream manual ball valve.
4. Using a screwdriver, slowly open the V1 test nipple (port 2) by turning it counter clockwise to depressurize the volume between the two valves, and connect the 1/4" flexible hose to the test nipple.
5. Slowly open the upstream manual ball valve, and then provide for some time to allow potential leakage to charge the test chamber before measuring the valve seat leakage.
6. Immerse the 1/4 in. tube vertically 1/2 in. (12.7 mm) below the water surface. If bubbles emerge from the 1/4" tube and after the leakage rate has stabilized, count the number of bubbles appearing during a 10 second period. (See chart below for allowable leakage rates.)
7. Repeat the same procedure for valve V2 (port 3).

After completing the above tests proceed as follows:

8. Verify that the downstream manual ball valve is closed, and both automatic safety shutoff valves are de-energized.
9. Remove the flexible hose, and close all test nipples.
10. With the upstream manual ball valve open, energize both automatic safety shutoff valves.
11. Use soapy water to leak test all test nipples to ensure that there are no leaks.
12. If no leakage is detected, de-energize all automatic safety shutoff valves, and open the downstream manual ball valve.

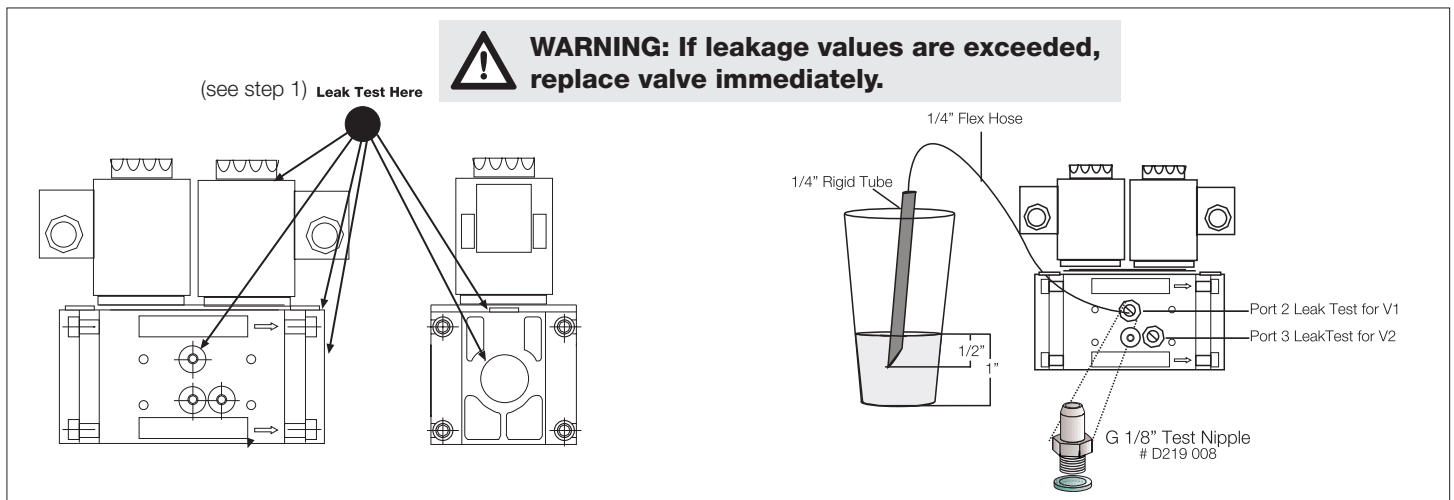

Type

Allowable Valve Seat Leakage* for up to 7 PSI inlet

of Bubbles in 10 sec AIR Natural Gas LP

DMV D(LE) 702/604L	464 cc/hr	9	11	7
DMV D(LE) 703/604L	464 cc/hr	9	11	7

*Based on air, and test conditions per UL 429 Section 29. (Air or inert gas at a pressure of 1/4 psig and also at a pressure of one and one-half times maximum operating pressure differential, but not less than 1/2 psig. This test shall be applied with the valve installed in its intended position.) Volume of bubble defined in Table 2 of FCI 70-2-1998.

FLOW CURVE

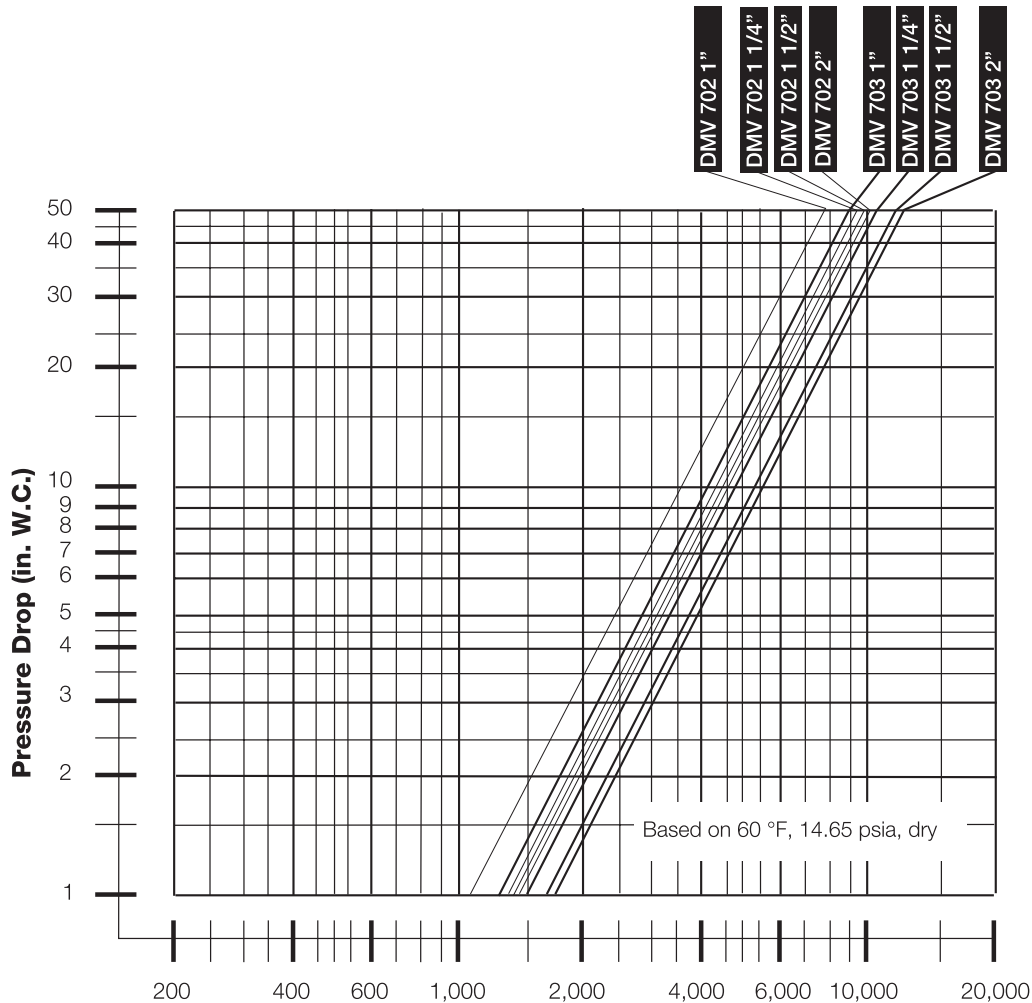

Flow (CFH) of natural gas s.g. 0.65 at 60 °F
20 in W.C. Inlet

PRESSURE DROP FOR OTHER GASES

To determine the pressure drop when using a gas other than natural gas, use the flow formula below and f value located in the chart below to determine the “corrected” flow rate in CFH through the valve for the other gas used. For example, when using propane, divide the volume (CFH) of propane required for the application by the calculated value f (f = 0.66 for propane). Use this “corrected” flow rate and the flow curve on above to determine pressure drop for propane.

$$\dot{V}_{\text{gas used}} = \dot{V}_{\text{Natural Gas}} \times f$$

Use this formula to calculator the f factor for other gases not listed on the table.

$$f = \sqrt{\frac{\text{Spec. gravity of Natural Gas}}{\text{Spec. gravity of gas used}}}$$

Type of gas used	Density [kg/m ³]	sg	f
Natural gas	0.81	0.65	1.00
Butane	2.39	1.95	0.58
Propane	1.86	1.50	0.66
Air	1.24	1.00	0.80

TEST PORTS

Test Ports

The G 1/8 ISO 228 taps are available on both sides upstream V1, between V1 and V2, downstream V2, and on both flanges. The G 1/8 test nipple (P/N 219-008) can be screwed in any of these pressure tap ports.

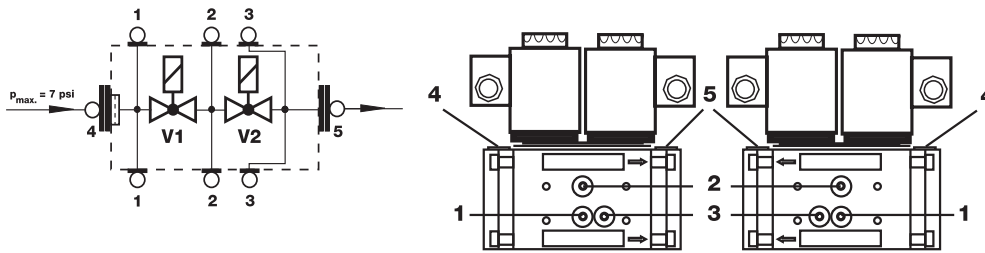

REPLACEMENT COILS

Type	Mag Type	Part # for 120VAC*
DMV-D(LE) 702/604L	151	D246 515
DMV-D(LE) 703/604L	152	D246 516

*Includes only one coil for one valve. If both coils need replacing, then order two of the above mentioned parts.

Other Replacement Parts and Accessories

Accessories/Adapters	P/N	Accessories/Adapters	P/N
CPI 400 valve switch	224-253A	Hydraulic Brake	240-458
Visual Indicator	217-665	Main Flow Adj. Knob	240-457
1/4" NPT port 1, port 2, or flange adapter (reduced port)	225-047		
1/2" NPT port 2 pilot gas adapter (reduced port)	225-043		
G 1/8" Test nipple	219-008		
Port 3 Pressure switch mounting adapter	214-975		
Replacement Hydraulic Brake for DLE versions	240-458		

Replacement Flanges

Valve Description	Flange Size	NPT P/N	Rp P/N	Oring and bolt kit for flanges P/N*
DMV-702 & 703	1"	222-369	222-343	224-094
DMV-702 & 703	1 1/4"	222-370	222-344	224-094
DMV-702 & 703	1 1/2"	222-003	221-884	224-094
DMV-702 & 703	2"	221-997	221-926	224-094

* Includes two orings for flanges and two sets of bolts (one set of four bolts for each flange).